

# Use & Care

**G U I D E**

## Electric and Gas Dryers

A Note to You .....	2
Dryer Safety .....	3-4
Getting to Know Your Dryer .....	5
Checking Your Vent ...	6
Operating Your Dryer .....	8
Caring for Your Dryer .....	14
Troubleshooting .....	19
Requesting Assistance or Service .....	21
Index .....	23
Warranty .....	24

**1-800-44-ROPER**

Call us with questions or comments.

PART NO. 3406073

**ROPER**<sup>®</sup>  
Home Appliances

6/97

# A NOTE TO YOU

## Thank you for buying a ROPER® appliance.

Your ROPER dryer gives you all the functionality of name brand appliances at a value price. To ensure that you enjoy years of trouble-free operation, we developed this Use and Care Guide. It is full of valuable information about how to operate and maintain your appliance properly and safely. Please read it carefully.

Also, complete and mail the **Product Registration Card** provided with your appliance. The card helps us notify you about any new information on your appliance.

## Please record your model's information.

Whenever you call to request service for your appliance, you need to know your complete model number and serial number. You can find this information on the model and serial number label (see the diagram on page 5 for the location of the label). Also, record the other information shown in the next column.

Model Number \_\_\_\_\_

Serial Number \_\_\_\_\_

Purchase Date \_\_\_\_\_

Dealer Name \_\_\_\_\_

Dealer Address \_\_\_\_\_

Dealer Phone \_\_\_\_\_

**Keep this book and the sales slip together in a safe place for future reference.**

**Our Consumer Assistance Center number is toll-free.**

**1-800-447-6737**

# DRYER SAFETY

## **Your safety is important to us.**

This guide contains safety statements under warning symbols. Please pay special attention to these symbols and follow any instructions given. Here is a brief explanation of the symbol.



This symbol alerts you to hazards such as fire, electrical shock, or other injuries.

**WARNING: For your safety, the information in this manual must be followed to minimize the risk of fire or explosion, or to prevent property damage, personal injury, or loss of life.**

- Do not store or use gasoline or other flammable vapors and liquids in the vicinity of this or any other appliance.
- **WHAT TO DO IF YOU SMELL GAS:**
  - Do not try to light any appliance.
  - Do not touch any electrical switch; do not use any phone in your building.
  - Clear the room, building, or area of all occupants.
  - Immediately call your gas supplier from a neighbor's phone.  
Follow the gas supplier's instructions.
  - If you cannot reach your gas supplier, call the fire department.
- Installation and service must be performed by a qualified installer, service agency, or the gas supplier.

continued on next page

# DRYER SAFETY

## IMPORTANT SAFETY INSTRUCTIONS

**WARNING** – To reduce the risk of fire, electric shock, or injury to persons when using the dryer, follow basic precautions, including the following:

- Read all instructions before using the dryer.
- Do not dry articles that have been previously cleaned in, washed in, soaked in, or spotted with gasoline, dry-cleaning solvents, other flammable, or explosive substances as they give off vapors that could ignite or explode.
- Do not allow children to play on or in the dryer. Close supervision of children is necessary when the dryer is used near children.
- Before the dryer is removed from service or discarded, remove the door to the drying compartment.
- Do not reach into the dryer if the drum is moving.
- Do not install or store the dryer where it will be exposed to the weather.
- Do not tamper with controls.
- Do not repair or replace any part of the dryer or attempt any servicing unless specifically recommended in this Use and Care Guide or in published user-repair instructions that you understand and have the skills to carry out.
- Do not use fabric softeners or products to eliminate static unless recommended by the manufacturer of the fabric softener or product.
- Do not use heat to dry articles containing foam rubber or similarly textured rubber-like materials.
- Clean lint screen before or after each load.
- Keep area around the exhaust opening and adjacent surrounding areas free from the accumulation of lint, dust, and dirt.
- The interior of the dryer and exhaust vent should be cleaned periodically by qualified service personnel.
- See Installation Instructions for grounding requirements.

**– SAVE THESE INSTRUCTIONS –**

# GETTING TO KNOW YOUR DRYER

The parts and features of your dryer are illustrated on this page. Become familiar with all parts and features before using your dryer. Page references are included next to some features. Refer to those pages for more information about the features.

**NOTE:** The drawings in this book may vary from your dryer model. They are designed to show the different features of all models covered by this book. Your model may not include all features.

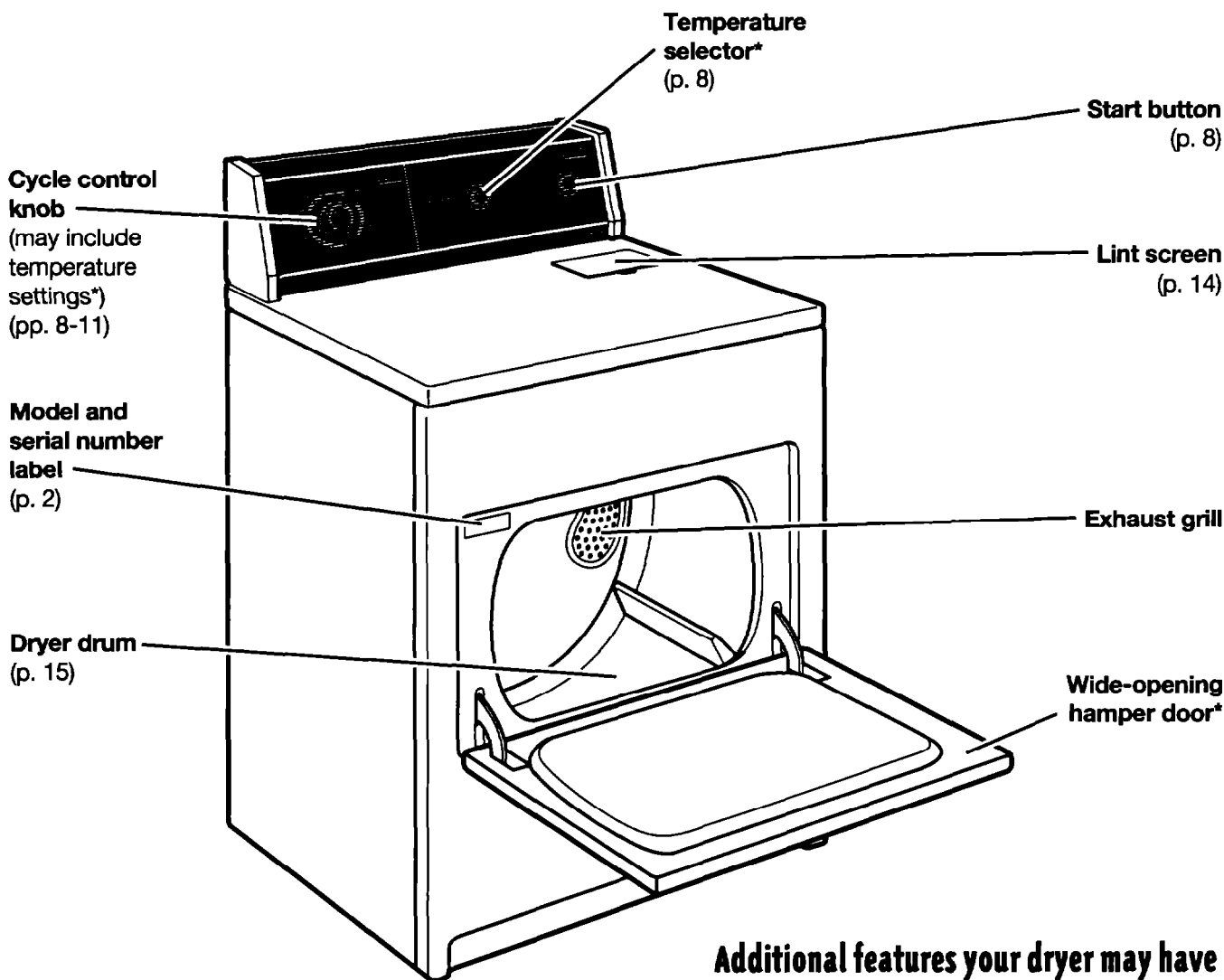

## Additional features your dryer may have

- End of cycle signal (p. 8)
- Drying rack (p. 13)
- Drum light (p. 16)

### Other doors:

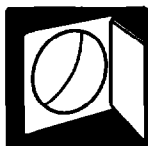

**Large side-swing door\***  
(Reversible door. See  
Installation Instructions)

\* On some models

# CHECKING YOUR VENT

Your dryer must be properly installed and vented to achieve maximum drying efficiency and shorten drying times. Install your dryer in a well-ventilated room where the temperature is always above 45°F (7°C). Also make sure that your dryer is leveled. Refer to your Installation Instructions for more information.

## VENTING

### ⚠ WARNING



#### Fire Hazard

- Use a heavy metal vent.
- Do not use a plastic vent.
- Do not use a metal foil vent.
- Failure to follow these instructions can result in death or fire.

If the dryer is not properly installed and vented, it will not be covered under the warranty.

**NOTE:** Service calls caused by improper venting will be paid for by the customer, whether it was a paid installation or self-installed. For paid installation, call the company that installed the vent for adjustment.

1. Four-inch heavy metal or flexible metal vent must

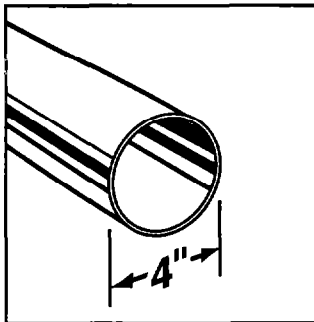

length requirements of vent.

be used. **Do not** use plastic vent or flexible metal foil vent. Do not kink or crush flexible metal vent. It must be completely extended to allow adequate exhaust air to flow. Check vent after installation. Refer to your Installation Instructions for proper

2. Use a 4" exhaust hood. Smaller hoods increase drying times.

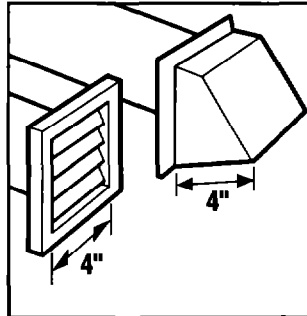

3. The exhaust vent can be routed up, down, left, right, or straight out the back of the dryer. Space requirements are listed in your Installation Instructions.

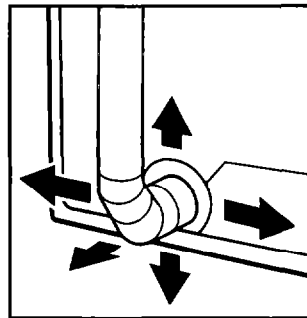

# VENTING (CONT.)

**4.** Use the straightest path possible when routing the exhaust vent. Avoid 90° turns, if possible. Allow room when using elbows or making turns. Bend vent gradually to avoid kinking.

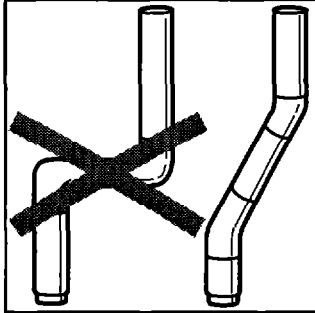

**5.** Use duct tape to seal all joints. **Do not** use screws to secure vent. Lint may catch on screws.

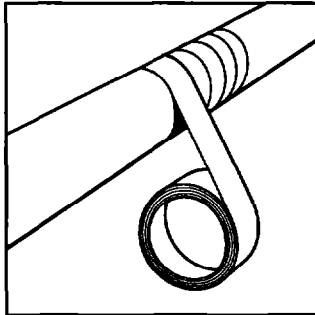

**6.** Clean exhaust vent periodically, depending on use, but at least every 2 years, or when installing your dryer in a new location.

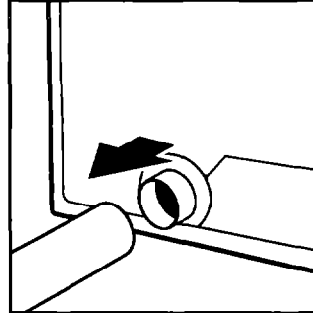

but at least every 2 years, or when installing your dryer in a new location.

- Disconnect vent from the dryer and clean one section at a time until you reach the exhaust hood.

- Use the hose attachment on your vacuum, or a pole or wire with a

feather duster or rag attached, to clean out lint.

- Be sure the flapper on the outside end of vent moves freely.

- When cleaning is complete, be sure to follow the Installation Instructions supplied with your dryer for final product check.

# OPERATING YOUR DRYER

To get the best dryer results possible, you must use your dryer correctly. This section tells you how to use your dryer properly and efficiently.

## STARTING YOUR DRYER

### ⚠ WARNING



#### Explosion Hazard

**Never place items in the dryer that are dampened with gasoline or other flammable fluids.**

**No washer can completely remove oil.**

**Do not dry anything that has ever had any type of oil on it (including cooking oils).**

**Doing so can result in death, explosion, or fire.**

Before using your dryer, wipe the dryer drum with a damp cloth to remove dust from storing and shipping.

- 1.** Load clothes loosely into the dryer and close the door. Do not pack the dryer; allow space for clothes to tumble freely.



- 2.** Turn the Cycle Control Knob to the recommended cycle for the type of load being dried, as described on pages 10 and 11.
- Use the Energy Preferred Automatic Setting (+) to dry most loads.
  - On some models, the Temperature selector is part of the Cycle Control Knob.

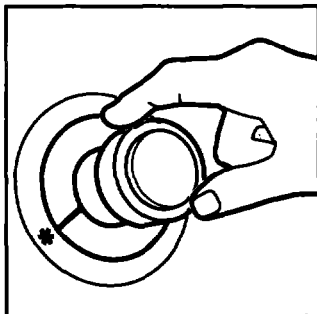

- 3.** If your dryer has a separate Temperature selector, set it to the recommended setting for the type of fabric being dried. The cycle descriptions on pages 10 and 11 include temperature setting suggestions.

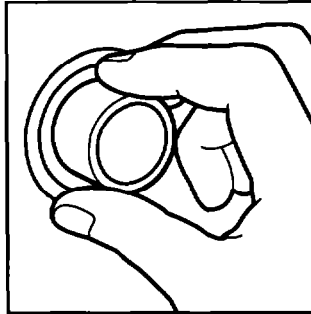

- 4. (OPTIONAL STEP)** If your dryer has an End of Cycle Signal selector, set the selector to On if you want the dryer to sound a signal when a cycle is finished.
- The End of Cycle Signal is part of the Start Button.
  - The signal is helpful when you are drying permanent press, synthetics, and other items that should be removed from the dryer as soon as it stops.

- 5.** Push the Start Button.

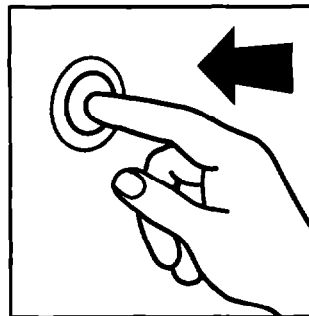

**NOTE:** Your dryer stops automatically when a cycle ends.



## STARTING YOUR DRYER (CONT.)

### Stopping and restarting your dryer

You can stop your dryer anytime during a cycle.

#### To stop your dryer:

Open the dryer door or turn the Cycle Control Knob to Off.

**NOTE:** The Cycle Control Knob should point to an Off area when the dryer is not in use.

#### To restart your dryer:

Close the door, select a new cycle and temperature (if desired), and push the Start Button.

## SELECTING THE RIGHT CYCLE AND TEMPERATURE SETTING

The following pages describe the drying cycles on your dryer. The descriptions include suggested temperature settings and drying times for various loads.

### Cycle and temperature tips

- Make sure you have selected the correct cycle and temperature for your load.
- Dry most loads using the Energy Preferred Automatic Setting (+).
- Use the No Heat/Fluff cycle, or line dry rubber, plastic, delicate, and heat-sensitive fabrics (see page 12).
- If some types of loads in the cycle descriptions on the following pages have more than one suggested temperature setting, choose the lowest setting available on your dryer.
- The last few minutes of all cycles are without heat to make the load cooler to handle.

### Drying tips

- Always follow care label directions when they are available.
- If you use fabric softener sheets, always use softener sheets that are labeled as dryer safe and follow package instructions carefully.
- Remove the load from the dryer as soon as tumbling stops to reduce wrinkling. This is especially important for permanent press, knits, and synthetic fabrics.

# CYCLE DESCRIPTIONS

## Automatic cycle(s)

Use an Automatic cycle to dry most loads. The Automatic cycle shuts off the dryer when the selected dryness is reached. The Cycle Control Knob does not move until the load is almost dry. After the cool-down, the Knob automatically turns to an Off area and tumbling stops.



- If the load is drier than you like, select a setting closer to **Less Dry** the next time you dry a similar load.
- If the load is not as dry as you like, complete drying using a Timed cycle. Select a setting closer to **Very Dry** the next time you dry a similar load.

Drying time with an Automatic cycle varies according to the type of fabric, size of load, and dryness setting. Your model may not have all heat settings listed. Some general guidelines are:

- Use a high heat setting for drying heavyweight items, such as towels and work clothes.
- Use a medium heat setting for drying mediumweight items, such as sheets, underwear, permanent press clothes, and some knits.
- Use a low heat setting for drying lightweight items such as lingerie, blouses, dresses, and some knits.

**NOTE:** If you have any questions about drying temperatures for various loads, refer to care label directions.

## Timed cycle(s)

Use a Timed cycles to complete drying if some items are damp after the Automatic cycle. The Timed cycle is also useful for:

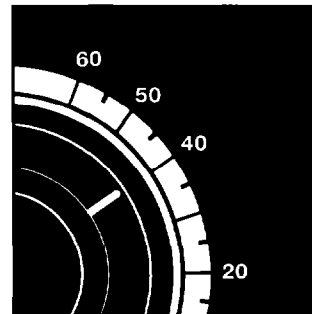

- Heavyweight and bulky items, such as bedspreads and work clothes, and large loads that require a long drying time. Set your dryer for High heat.

- Lightweight items, such as lingerie, blouses, and knits that require a short drying time. Set your dryer for Low heat.
- Drying time and temperature will depend on your dryer model.

## No Heat/Fluff cycle (on some models)

Use the unheated No Heat/Fluff cycle for items that require drying without heat. The chart on page 12 includes examples of items that require drying without heat.

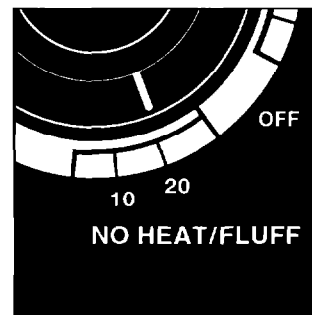

**NOTE:** If your model does not have the No Heat/Fluff cycle, line dry heat-sensitive items.

## Damp Dry feature (on some models)

Use the Damp Dry feature in the Timed cycle to dry items to damp level or to dry items that do not require an entire drying cycle. Two examples are heavy cottons, such as jeans, which you do not want to become stiff, or cotton clothes which are easier to press when damp. Set the Temperature selector to High heat.

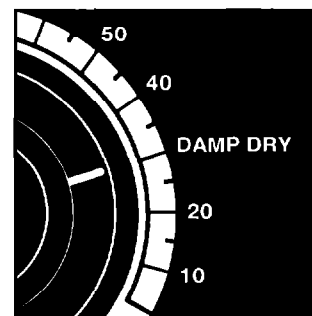

## CYCLE DESCRIPTION (CONT.)

### Wrinkle Free feature (on some models)

The Wrinkle Free feature in the Timed cycle removes wrinkles from clothes that have been packed in a suitcase or closet, or from items not removed from the dryer at the end of a cycle. As soon as the dryer stops, fold or put the items on hangers. Set the Temperature selector to Medium or Low heat.



### WRINKLE PREVENT™ feature (on some models)

When you are unable to remove a load from the dryer as soon as it stops, wrinkles can form. The WRINKLE PREVENT feature tumbles the load without heat every few minutes up to 45 minutes after the cycle ends. This tumbling rearranges and fluffs the load to avoid wrinkles.



You do not have to set the Cycle Control Knob for the WRINKLE PREVENT feature. If you do not open the dryer door within a few minutes after the cycle stops, the WRINKLE PREVENT feature takes over to protect the load.

A signal sounds every few minutes when WRINKLE PREVENT is running. The signal and cycle stop when you open the dryer door.



# USING THE DRYING RACK

Your dryer may include a drying rack. If your model doesn't include one, you can order a drying rack by calling **1-800-447-6737**, from anywhere in the U.S.A. You will hear a recording. Follow the instructions to place an order.

The drying rack lets you dry items without tumbling them. The rack does not move, but the drum turns.

- 1.** Fit rear pegs of the rack into spaces in the back wall of the dryer. Lower the front so the legs rest on the dryer opening.

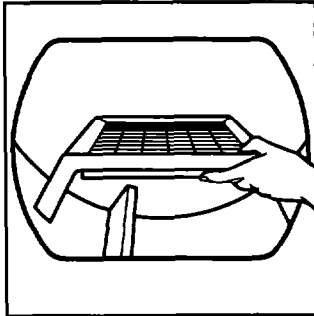

- 2.** Put wet items on top of the rack. Leave space between the items so air can reach all surfaces.

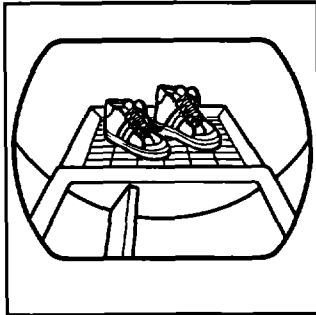

● See chart below for suggested cycles and settings for items that might best be rack dried. Drying time will depend on amount of moisture items hold.

**NOTE:** Make sure nothing hangs over the edge of the rack.

- 3.** Close the door.

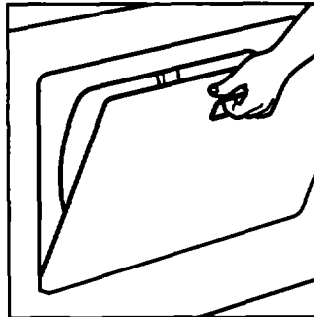

- 4.** Select a Timed cycle and temperature, or the No Heat/Fluff cycle.

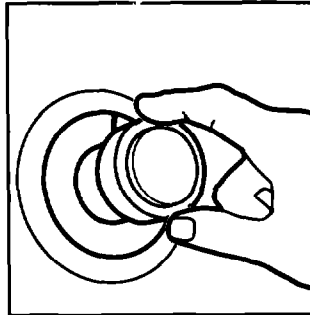

- 5.** Push the Start Button.

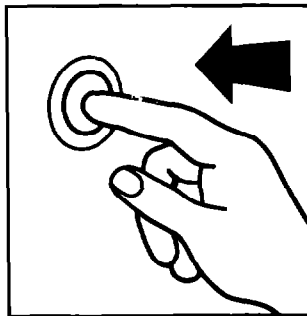

**NOTE:** The rack must be removed for normal tumbling. Automatic cycles do not work with the drying rack.

RACK DRY	CYCLE	TEMPERATURE	TIME* (minutes)
<b>Wool sweaters</b> (Block to shape and lay flat on the rack)	Timed	Low	60
<b>Stuffed toys or pillows</b> (Cotton or polyester fiber filled)	Timed	Low	60
<b>Stuffed toys or pillows</b> (Foam rubber filled)	No Heat/Fluff	None; cycle is unheated.	90
<b>Sneakers or canvas shoes</b>	No Heat/Fluff	None; cycle is unheated.	30-40

\* Reset cycle as needed to complete drying.

# CARING FOR YOUR DRYER

Proper care of your dryer can extend its life and help your dryer operate efficiently.

## CLEANING THE LINT SCREEN

### Every load cleaning

The lint screen is located under a lid on top of the dryer. **Clean it before each load.** A screen blocked by lint can increase drying time.

#### To clean:

1. Open the lid and pull the lint screen towards you.

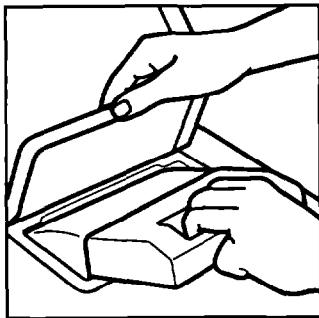

2. Roll lint off the screen with your fingers. Do not rinse or wash screen to remove lint. Wet lint is hard to remove.



3. Push the lint screen firmly back into place and close the lid.

#### IMPORTANT:

- Do not run the dryer with the lint screen loose, damaged, blocked, or missing. Doing so can cause overheating and damage to both the dryer and fabrics.
- Some towels made of synthetic fibers and natural fibers (polyester and cotton blends) may shed more lint than other towels, causing your dryer's lint screen to fill up faster. Be sure to remove lint from the lint screen before and after drying new towels.

### As needed cleaning

Laundry detergents and fabric softeners can cause a residue buildup on the lint screen. This buildup can cause longer drying times for your clothes, or cause the dryer to stop before your load is completely dry. You may be able to see this buildup, or the lint may be falling off the screen because it is clogged.

Clean the lint screen with a nylon brush every six months or more frequently if it becomes clogged due to a residue buildup.

#### Use the following method:

1. Wet both sides of lint screen with hot water.
2. Wet a nylon brush with hot water and liquid detergent; scrub lint screen with the brush to remove residue buildup.

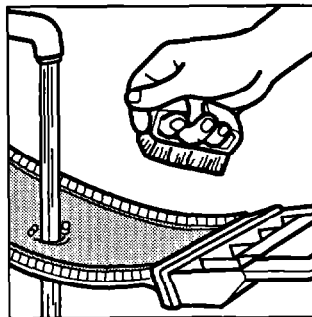

detergent; scrub lint screen with the brush to remove residue buildup.

3. Rinse screen with hot water.
4. **Thoroughly** dry lint screen with a clean towel; replace in dryer.

## CLEANING THE DRYER INTERIOR

Garments which contain unstable dyes, such as denim blue jeans or brightly colored cotton items, may discolor the dryer interior. These stains are **not** harmful to your dryer and will not stain future loads of clothes. It is helpful to dry unstable dye items inside out to prevent dye transfer.

### To clean dryer drum:

1. Make a paste with powdered laundry detergent and very warm water.
2. Apply paste to a soft cloth.

### OR

Apply a liquid, non-flammable household cleaner to the stained area and rub with a soft cloth until all excess dye is removed.



3. Wipe drum thoroughly with a damp cloth.
4. Tumble a load of clean cloths or towels to dry drum.

## ⚠ WARNING



### Explosion Hazard

**Use nonflammable cleaner.**

**Failure to do so can result in death, explosion, or fire.**

## CHANGING THE DRUM LIGHT

The dryer light automatically turns on inside the dryer drum when you open the door. See instructions below to change your drum light.

### ⚠ WARNING



#### Fire Hazard

Replace light bulb cover before operating dryer.

Failure to do so can result in death or fire.

### To change drum light:

1. Unplug the dryer or disconnect the electricity leading to the dryer at the main power supply.
2. Open the dryer door. Remove the light bulb cover from the back wall of the dryer by removing the screw located in the lower right corner of the cover.

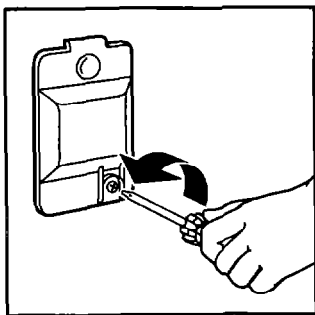

3. Remove the light bulb by turning it counterclockwise.

4. Replace the bulb with a 10-watt appliance bulb only.
5. Replace the light bulb cover.

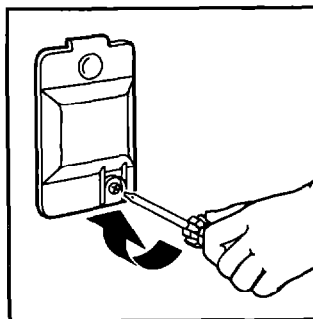

6. Reconnect power supply.



# REMOVING ACCUMULATED LINT FROM INSIDE THE DRYER CABINET

Lint can gather inside the dryer and be a fuel for fire. Lint should be removed every two to three years, or more often, depending on dryer usage. Cleaning should be done by a qualified person. If you have any questions or comments, please call our Consumer Assistance Center at 1-800-447-6737 from anywhere in the U.S.A.

## ⚠ WARNING



**Electrical Shock Hazard**  
**Disconnect power before cleaning.**  
**Replace all panels before operating.**  
**Failure to do so can result in death or electrical shock.**

1. Unplug dryer or turn off power supply.
2. Remove rear panel.
3. Remove any lint using a vacuum cleaner or soft brush. Avoid damaging wires and thermostats.
4. Replace rear panel.

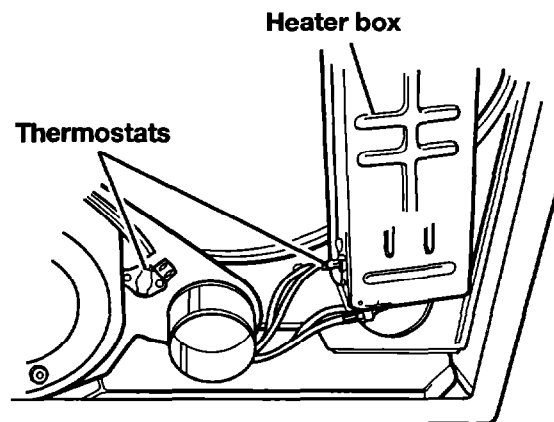

Dryer with rear panel removed

5. Open lint screen lid. Remove 2 screws from lint screen area.
6. Open top by pulling forward and up at each front corner (see illustration). Rest raised top against wall behind dryer (top is hinged at rear).

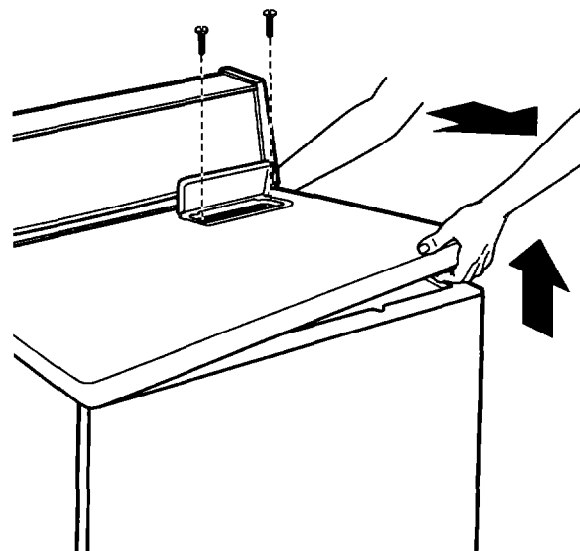

continued on next page

## REMOVING ACCUMULATED LINT FROM INSIDE THE DRYER CABINET (CONT.)

7. Remove 2 internal screws from front panel flanges (near top front corners). Lift front panel slightly, lifting off lower clips (see lower clip inset of illustration below). Slowly pull front panel forward, disengaging panel from drum. (Drum will drop slightly.)
8. Move front panel aside and rest edge against side of dryer. Avoid disconnecting wire clips (see wire clips inset of illustration below) or damaging wires.
9. Remove any lint using a vacuum cleaner or soft brush.

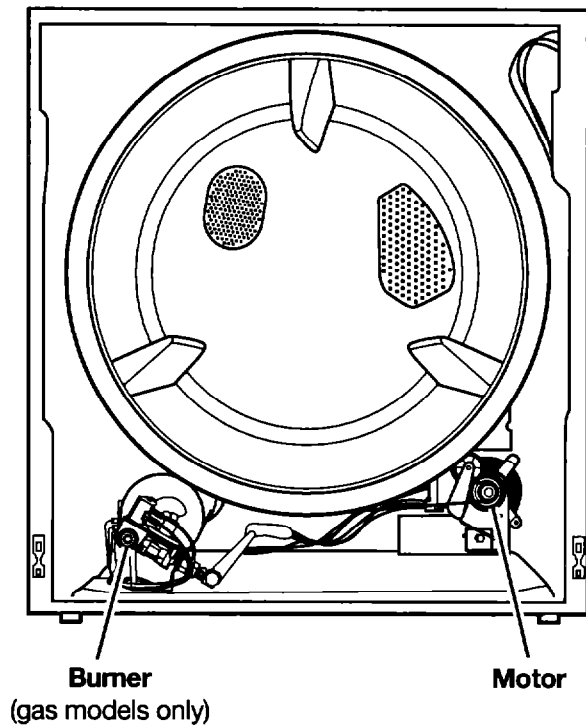

Dryer with front panel removed

10. Reassemble in reverse order. Before closing the top, check the following:
  - Drum seal must be flared out (see drum seal insets of illustration) and properly positioned against panel at back of drum. Rotate drum counterclockwise one full turn to check drum seal.
  - Belt should be centered and tight on dryer drum.
  - Wire clip retainer, which holds the door switch wires, must be secured to top of front panel (see wire clips inset of illustration) and along top edge of side panel. Door wires must not touch drum when dryer is operating.
11. Replace top panel and lint screen screws. Top and front panels must be securely in place before operating dryer.
12. Level the dryer if necessary.
13. Plug in dryer or turn on power supply.

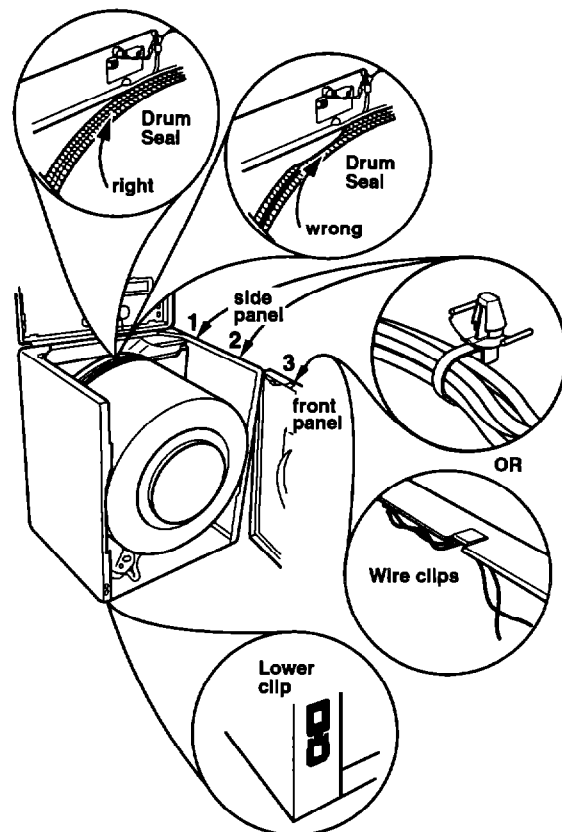

# TROUBLESHOOTING

Most laundering problems are easily solved if you understand the cause. Check the following list for **common laundry problems** and the next page for **common dryer problems**. If you need further assistance, see "Requesting Assistance or Service" on page 21.

**NOTE:** In the following list, the most common laundry problems are listed first.

## COMMON LAUNDRY PROBLEMS

Problem ...	Cause ...
Slow drying or clothes still wet	<ul style="list-style-type: none"> <li>● Incorrect cycle or temperature setting selected.</li> <li>● Full or clogged lint screen. (See page 14.)</li> <li>● Exhaust vent clogged, restricted, or too long. (See pages 6-7 and Installation Instructions.)</li> <li>● Dryer located in room with temperature below 45° (7°C).</li> <li>● Load too large and bulky to dry quickly.</li> <li>● Drying heavy fabrics (denim, towels) with light fabrics (synthetics, permanent press).</li> <li>● Fabric softener sheet blocking exhaust grill inside dryer drum.</li> </ul>
Lint	<ul style="list-style-type: none"> <li>● Full lint screen. (See page 14.)</li> <li>● Load not properly sorted.</li> <li>● Overdrying, especially synthetic fabrics that cause lint-attracting static electricity.</li> <li>● Load size too big or heavy.</li> <li>● Tissue or paper left in pockets.</li> <li>● Pilling (surface fuzz caused by normal wear and laundering) attracts lint.</li> </ul>
Static electricity	<ul style="list-style-type: none"> <li>● Overdrying.</li> <li>● Dryer fabric softener improperly used. See package directions.</li> <li>● Load includes synthetics, synthetic blends, permanent press, and knit fabrics that build up static electricity.</li> </ul>
Wrinkling	<ul style="list-style-type: none"> <li>● Overloading.</li> <li>● Overdrying, especially permanent press and synthetic fabrics.</li> <li>● Large items balling or rolling up.</li> <li>● Clothes left in dryer at end of cycle.</li> </ul>
Shrinking	<ul style="list-style-type: none"> <li>● Overdrying.</li> <li>● Fabric or garment is not designed for tumble drying.</li> <li>● Dryer settings incorrect for fabric type.</li> <li>● Care label instructions not followed.</li> </ul>
Greasy spots/stains	<ul style="list-style-type: none"> <li>● Dryer fabric softener improperly used. Do not add to a warm load.</li> <li>● Drying soiled items.</li> </ul>
Color change	<ul style="list-style-type: none"> <li>● Drying dark colors with light colors.</li> <li>● Drying colorfast colors with non-colorfast colors.</li> </ul>
Garment damage	<ul style="list-style-type: none"> <li>● Zippers, snaps, and hooks left open.</li> <li>● Strings and sashes not tied to prevent tangling.</li> <li>● Care label instructions not followed.</li> </ul>

# COMMON DRYER PROBLEMS

## 1. Dryer will not start.

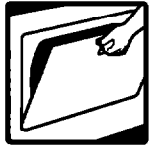

Is the dryer door firmly closed?



Are the controls set in an ON position?



Did you firmly push the Start Button?



Is the power cord plugged in?

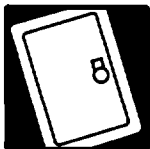

Have you blown a fuse or tripped a circuit breaker? Electric dryers use 2 household fuses or breakers.

## 2. Lint accumulation in hood or exhaust vent, or extended drying times.



Is lint screen full?



Is exhaust vent or outside exhaust hood clogged with lint? Refer to venting section on pages 6-7.

## 3. No heat



For gas dryers, is the valve open on the supply line? Also, some dryers may have an internal gas valve. See Installation Instructions.

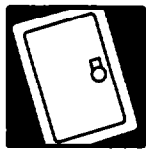

For electric dryers, have you blown a fuse or tripped a circuit breaker? Electric dryers use 2 household fuses or breakers. The drum may be turning but you may not have heat.

## 4. Noises



If the dryer hasn't been used for awhile, there may be a thumping sound during the first few minutes of operation.

If noises continue, call the Consumer Assistance Center.

## 5. Odor



When operating a new dryer, the new electric heating element may have an odor.

Are household chemical odors being drawn into dryer? Proper ventilation must be used if painting or staining near the dryer.

**NOTE:** Store and use paints, varnishes, etc. away from your dryer whenever possible.

If you still have problems, see "Requesting Assistance or Service" on page 21.

# REQUESTING ASSISTANCE OR SERVICE

To avoid unnecessary service calls, please check "Troubleshooting" on pages 19-20. It may save you the cost of a service call. If you still need help, follow the instructions below.

## IF YOU NEED ASSISTANCE OR SERVICE

Call the Consumer Assistance Center toll free at 1-800-447-6737. Our consultants are available to assist you.



When calling:

Please know the purchase date, and the complete model and serial number of your appliance (see page 2). This information will help us better respond to your request.

**Our consultants provide assistance with:**

- Features and specifications on our full line of appliances
- Installation information
- Use and maintenance procedures

- Accessory and repair parts sales
- Do-it-yourself repair help
- Specialized customer assistance (Spanish speaking, hearing impaired, limited vision, etc.)
- Referrals to local dealers, service companies, and repair parts distributors

**Service technicians** are trained to fulfill the product warranty and provide after-warranty service, anywhere in the United States.

To locate the authorized service company in your area, you can also look in your telephone directory Yellow Pages.

## IF YOU NEED REPLACEMENT PARTS

If you need to order replacement parts, we recommend that you only use FSP® factory authorized parts. FSP replacement parts will fit right and work right, because they are made to the same exacting specifications used to build every new ROPER® appliance.

To locate FSP replacement parts in your area, call our Consumer Assistance Center telephone number or your nearest authorized service center.

## FOR FURTHER ASSISTANCE

If you need further assistance, you can write to Whirlpool with any questions or concerns at:

Roper Brand Home Appliances  
Consumer Assistance Center  
c/o Correspondence Dept.  
2000 North M-63  
Benton Harbor, MI 49022-2692

Please include a daytime phone number in your correspondence.

If the dealer, authorized servicer, and Whirlpool have failed to resolve your problem, you can contact the Major Appliance Consumer Action Program (MACAP). MACAP is a group of independent consumer experts that voice consumer views at the highest levels of the major appliance industry. MACAP will in turn inform us of your action.

Major Appliance Consumer Action Program  
20 North Wacker Drive  
Chicago, IL 60606

# INDEX

This index is alphabetical. Look for the word or phrase you are interested in, then look for the page number.

<u>TOPIC</u>	<u>PAGE</u>	<u>TOPIC</u>	<u>PAGE</u>
ASSISTANCE .....	21	END OF CYCLE SIGNAL .....	8
CARE/CLEANING		ENERGY PREFERRED SETTING .....	8-9
Dryer interior .....	15	LINE DRYING .....	12
Lint screen .....	14	LINT	
CHOOSING LOAD SIZES .....	8-12	Removal .....	17
CYCLES		Screen .....	14
Automatic .....	10	RACK DRY .....	13
Damp Dry .....	10	SELECTING CYCLE/SETTING .....	9-12
No Heat/Fluff .....	9-10, 12	SERVICE .....	21
Timed .....	10	START BUTTON .....	8
Wrinkle Free .....	11	TEMPERATURE SELECTOR .....	8-12
WRINKLE PREVENT™ .....	11	TROUBLESHOOTING	
DRUM LIGHT .....	16	Dryer problems .....	20
DRYER		Laundry problems .....	19
Features .....	5	VENTING .....	6-7
Restarting .....	9	WARRANTY .....	24
Safety .....	3-4		
Starting .....	8		
Stopping .....	9		
DRYING			
Cycles .....	10-12		
Rack .....	13		

# WARRANTY

## WHIRLPOOL® DRYER

<b>LENGTH OF WARRANTY</b>	<b>WHIRLPOOL WILL PAY FOR</b>
<b>FULL ONE-YEAR WARRANTY FROM DATE OF PURCHASE</b>	FSP® replacement parts and repair labor to correct defects in materials or workmanship. Service must be provided by an authorized Whirlpool service company.
<b>WHIRLPOOL WILL NOT PAY FOR</b>	
<p><b>A. Service calls to:</b></p> <ol style="list-style-type: none"> <li>1. Correct the installation of your dryer, including venting. Heavy four-inch metal exhaust vent must be used. Refer to the venting section of this manual and your Installation Instructions.</li> <li>2. Instruct you how to use your dryer.</li> <li>3. Replace house fuses or correct house wiring or plumbing.</li> <li>4. Replace light bulbs.</li> </ol> <p><b>B. Repairs when your dryer is used in other than normal, single-family household use.</b></p> <p><b>C. Pickup and delivery.</b> Your dryer is designed to be repaired in the home.</p> <p><b>D. Damage to your dryer caused by accident, misuse, abuse, improper installation (including, but not limited to, venting with plastic or flexible foil), installation not in accordance with local electrical or plumbing codes, use of products not approved by Whirlpool, or acts of God.</b></p> <p><b>E. Repairs to parts or systems caused by unauthorized modifications made to the appliance.</b></p>	
10/96	

**WHIRLPOOL CORPORATION SHALL NOT BE LIABLE FOR INCIDENTAL OR CONSEQUENTIAL DAMAGES.**

Some states do not allow the exclusion or limitation of incidental or consequential damages, so this exclusion or limitation may not apply to you. This warranty gives you specific legal rights, and you may also have other rights which vary from state to state.

**Outside the United States, a different warranty may also apply. For details, please contact your authorized Whirlpool dealer.**

If you need service, first see the "Troubleshooting" section of this book. After checking "Troubleshooting," additional help is available by checking the "Requesting Assistance or Service" section, or by calling our Consumer Assistance Center telephone number, **1-800-253-1301**, from anywhere in the U.S.A.